



Familia VERON

produse

pagina

Coș cu capac	12
Coș fără capac	12
Bancă	66
Scaun	66
Bancă dublă	68
Banchetă	69
Masă	100
Suport bicicletă	184





Coș Veron
44040103-V

caracteristici

- corp și capac confecționate din oțel, zincate termic și vopsite în câmp electrostatic
- corp îmbrăcat cu rigle din lemn tratat cu lazură ecologică
- prevăzut cu inel suport pentru sac menajer și elemente de asamblare din inox
- capacitate utilă: 56 litri
- masă: 31 kg, respectiv 22 kg

fixare, golire

- prin fixarea corpului principal pe piesa de ancorare betonată sau cu conexanduri, dibluri
- cu saci menajeri sau recipient interior ignifug

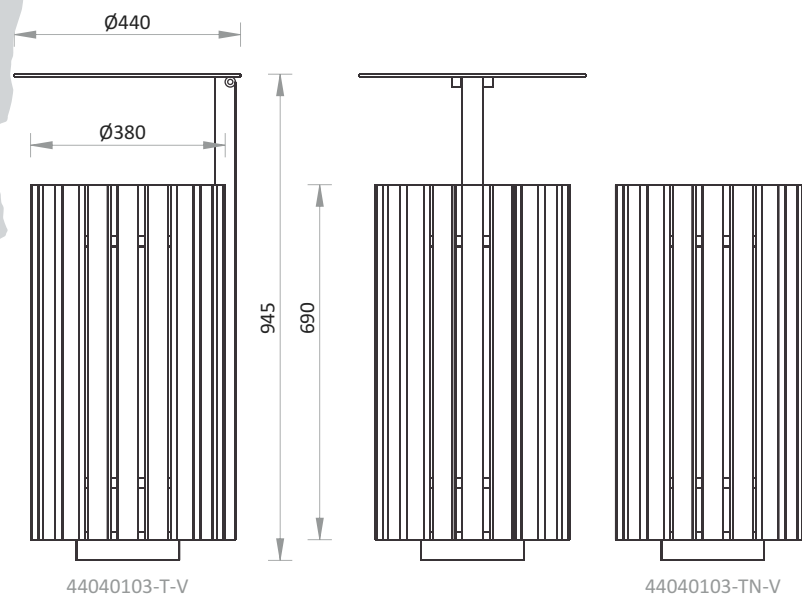
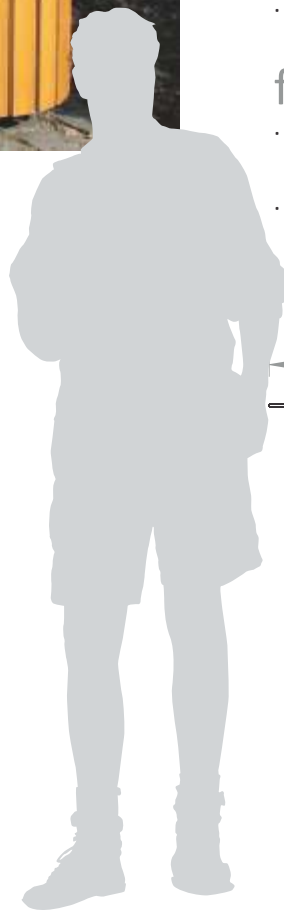



Bancă Veron
44010111-T185-V

Scaun Veron
44010111-T60-V



caracteristici

- suport din țevă de oțel, zincat termic și vopsit în câmp electrostatic
- scânduri din lemn tratat cu lazură ecologică, de 40 mm grosime
- elemente de asamblare din inox
- masă: Bancă Veron - 30 kg
Scaun Veron - 20 kg

fixare

- cu conexpanduri, dibluri

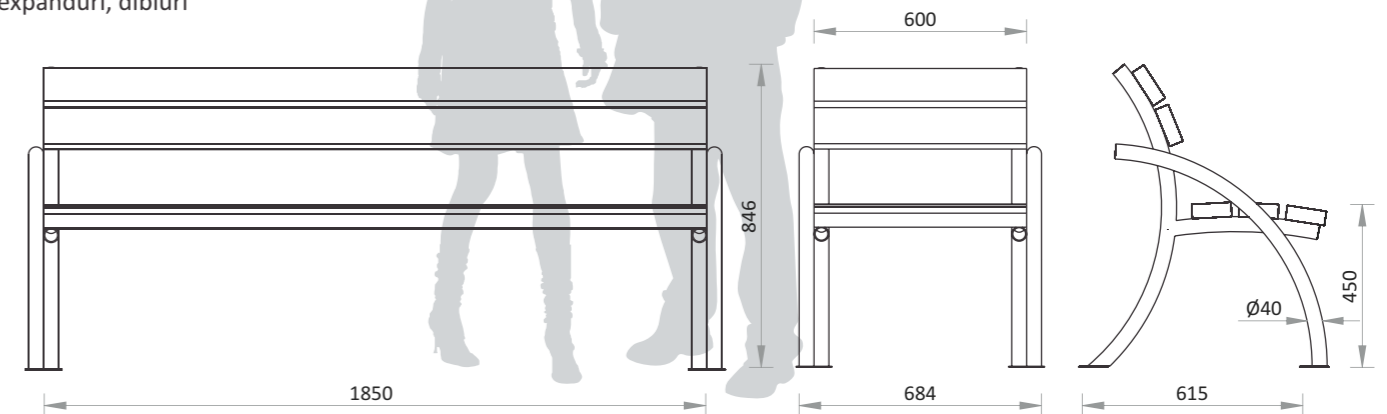



Bancă Veron dublă
44010111-TD-V

caracteristici

- suport din țevă de oțel, zincat termic și vopsit în câmp electrostatic
- scânduri din lemn tratat cu lazură ecologică, de 40 mm grosime
- elemente de asamblare din inox
- masă: 76 kg

fixare

- cu conexpanduri, dibluri

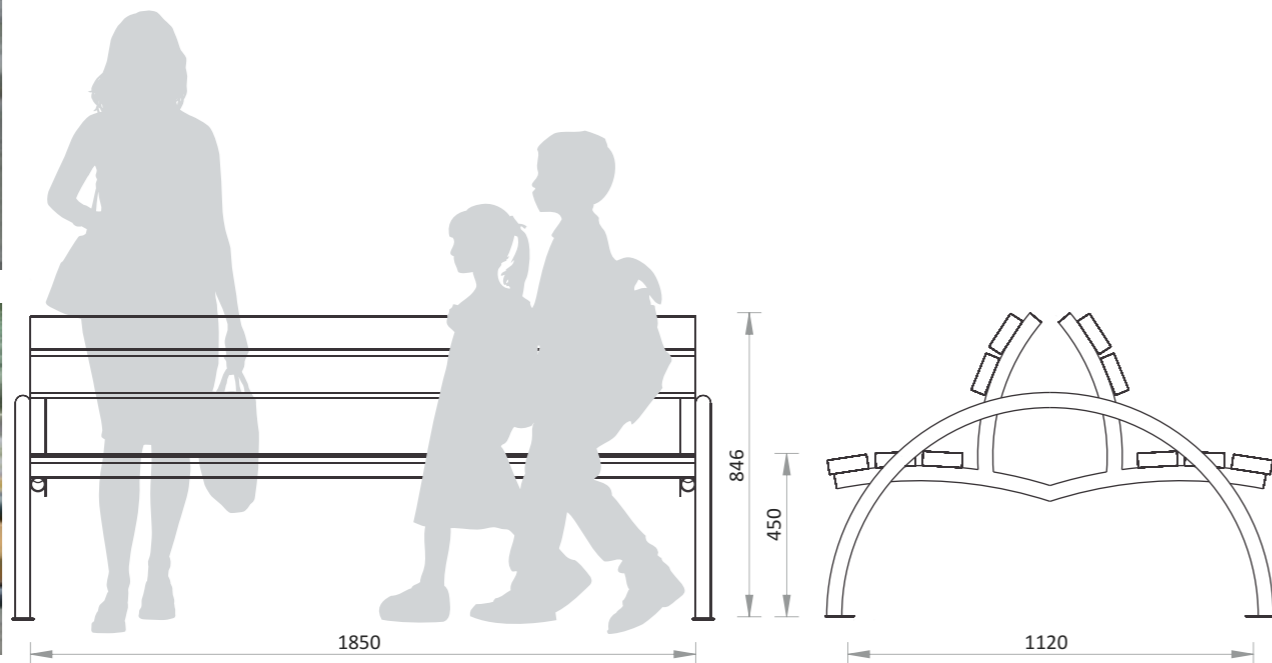

Banchetă Veron
44010111-TN-V



caracteristici

- suport din țevă de oțel, zincat termic și vopsit în câmp electrostatic
- scânduri din lemn tratat cu lazură ecologică, de 40 mm grosime
- elemente de asamblare din inox
- masă: 26 kg

fixare

- cu conexpanduri, dibluri

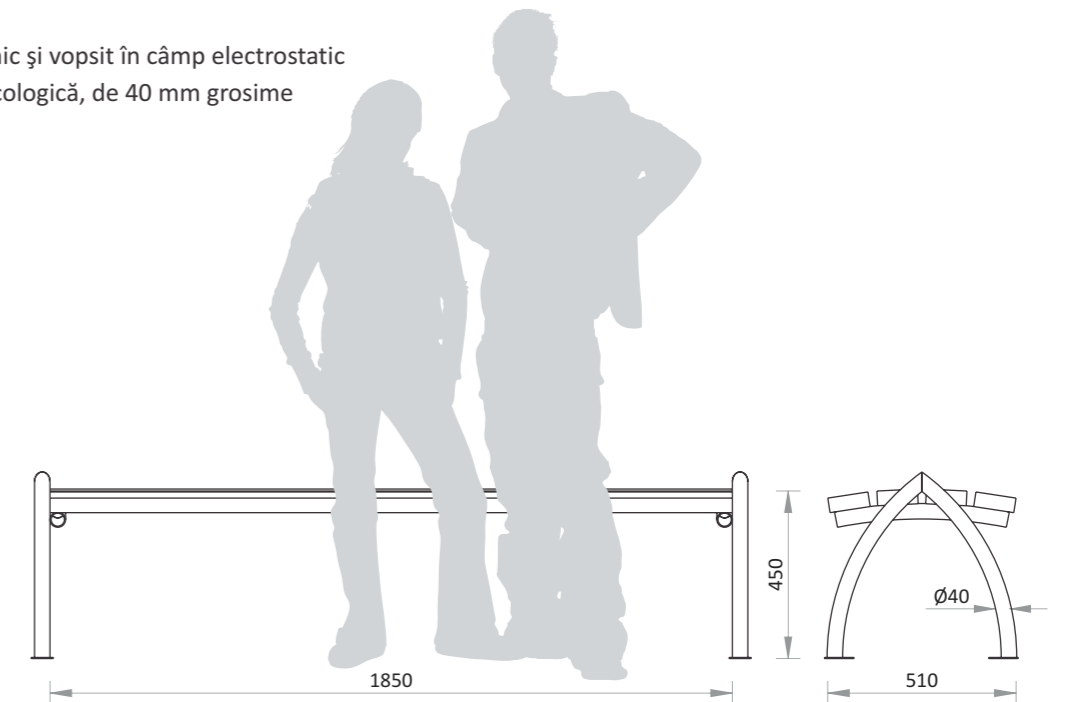



Masă Veron
44010204-V

caracteristici

- suport din profile de oțel, zincat termic și vopsit în câmp electrostatic
- scânduri din lemn tratat cu lazură ecologică, de 40 mm grosime
- elemente de asamblare din inox
- masă: 48 kg

fixare

- cu conexpanduri, dibluri

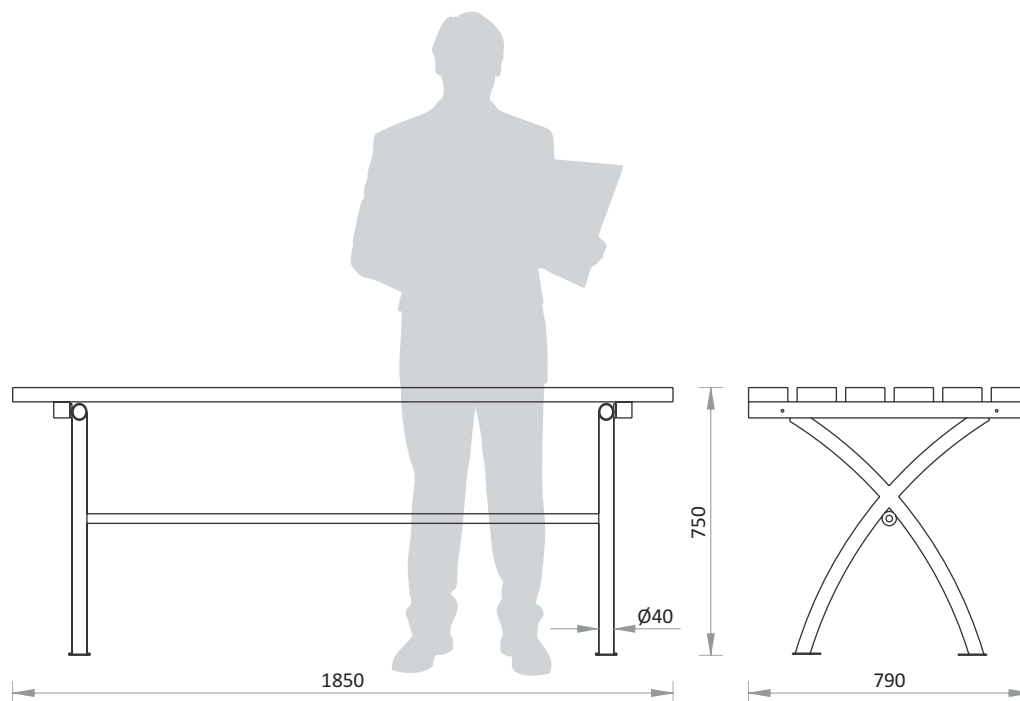



Suport Veron

44040204-V

caracteristici

- suport din țeavă de oțel, zincat termic și vopsit în câmp electrostatic
- se poate comanda cu 4-6 locuri/rastel, cu posibilitate de montare în șir continuu
- elemente de asamblare din inox
- masă: 45 kg

fixare

- cu conexpanduri, dibluri

